

Electrical Troubleshooting Guide for the Portofino Pro

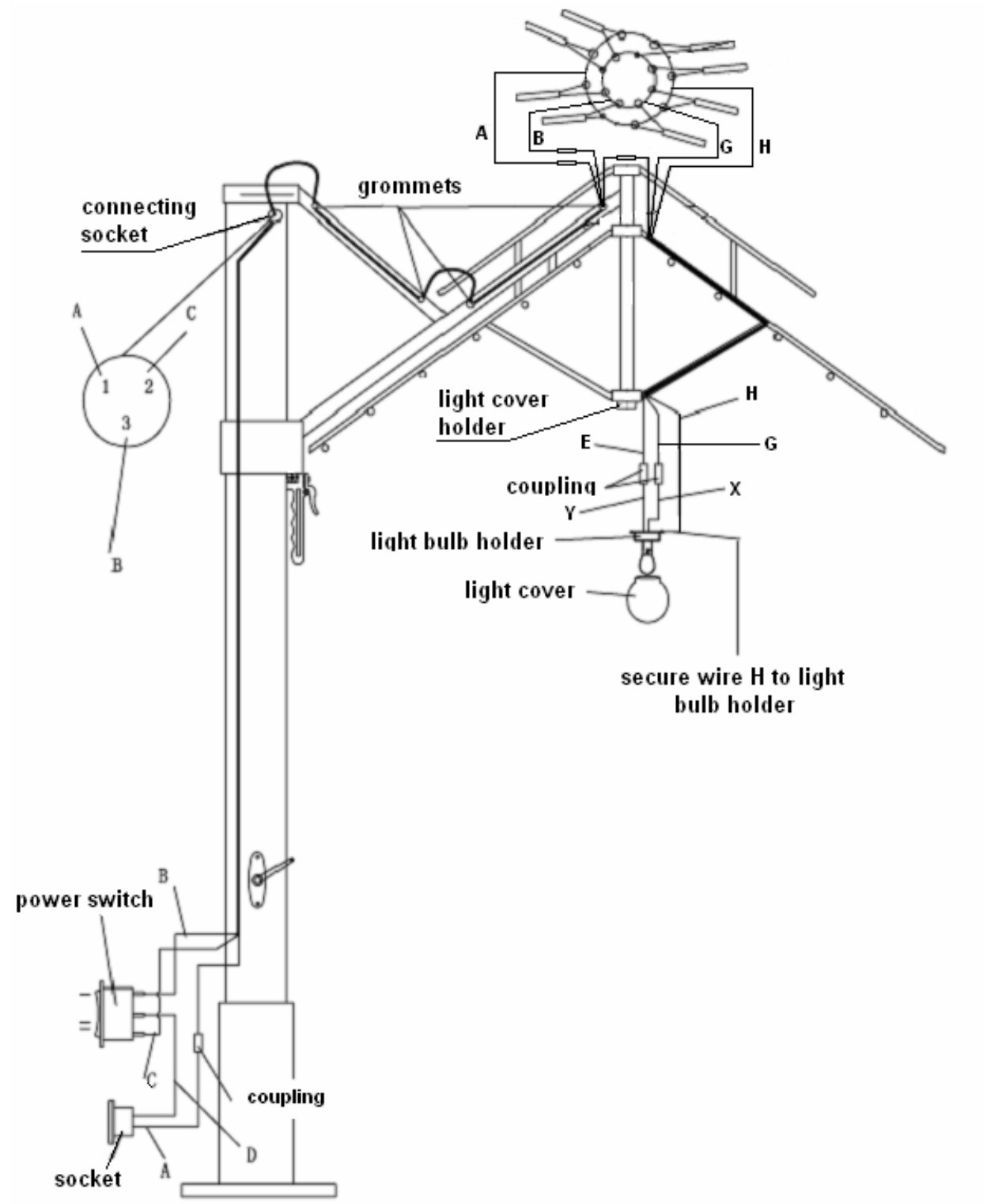

For further assistance contact our service department

Instructions for checking the light system of the Portofino Pro

CAUTION: Always unplug any electrical appliance before attempting any repairs.

THE CORRECT OPERATING INSTRUCTIONS:

When the switch is in the “---“ position, the moon light is bright and star lights are off. When the switch is in the “==“ position, the moon light is dim and star lights are bright.

WIRE LAYOUT

MAIN POST: Power Switch: Wire B corresponds with --- and wire C corresponds with ==. Wire A is attached to one terminal on the Power Socket and wire D is connected to the other terminal on the Power Socket and to the center terminal of the Power Switch.

APPLIANCE MANTLE: Wire B from the Lower Support Arm is attached to the Inside Ring and wire A is attached to Outside Ring. Wire H from the Long Rib is attached to the Outside Ring and wire G is attached to Inside Ring. Wire C from the lower support arm is connected to wire E from the long rib.

LIGHT COVER HOLDER: Wire H is attached to the Light Bulb Holder. Wire E is connected to wire Y at the Light Bulb Holder. Wire G is connected to wire X at the Light Bulb Holder.

TROUBLESHOOTING STEPS

Problem #1 - Moon light is off, but star lights are on

** When the switch is in the “---“ position, the star lights are not on.

** When the switch is in the “==“ position, please do the following steps.

1. Check the two wires on the light cover holder and light bulb holder. Make sure the E wire and the Y wire are properly connected at the coupling. Make sure the wires are not broken or cut.

Make sure wire G and wire X are properly connected at the coupling. Make sure the wires are not loose or broken.

2. Check the weld of wire Y and wire X on the light bulb holder. Make sure they are not loose or broken. Re-weld or replace the wire on the light bulb holder, if necessary.
3. Check to make sure wire C and wire E are properly connected at the coupling. Make sure the wires are not loose or broken.
4. Check wire H to make sure it is properly connected at light bulb holder. Make sure the wire is not loose or broken.

Problem #2 - Star lights are off, but the moon light is on

** When the Power Switch is in the "--" position it is normal that the star lights are off.

** When the Power Switch is in the "==" position, please do the following steps.

1. Check to make sure wire B outside the appliance mantle, is properly connected at the coupling. Make sure the wire is not loose or broken.
2. Check to make sure wire B and wire G are firmly connected to the Inside Ring in the appliance mantle.
3. Check to make sure wire A and wire H are properly connected to the Outside Ring in the appliance mantle.

Problem #3 - Moon light and star lights are both off

1. Check to make sure wire B is properly connected at the coupling outside the Appliance Mantle. Make sure wire C and wire E are properly connected together at the coupling. Make sure wire A is properly connected at the coupling.
2. Check to make sure wire B and wire G are properly connected to the inside ring and wire H and wire A are properly connected to the outside ring inside appliance mantle. Retighten all the screws.
3. Check to make sure wire E and wire Y are properly connected together at the coupling. Wire G and wire X are properly connected together at the coupling. Make sure all the wires are not loose or broken.
4. Check to make sure wire H is properly attached to the light bulb holder.

5. Check the weld points on wires X & Y at the light bulb holder.
6. Check to make sure wire C, wire D and wire B are properly connected to the Power Switch.
7. Check to make sure wire A and wire D are properly connected to the Power Socket.
8. Check the transformer for external damaged. The input AC power 110V/or 220V, the output DC power 12V. Make sure the wires are not cut or broken.
9. Check the plug and socket at the top of the Main Post. Make sure the plug and socket are properly connected together. Check welding points on 1, 2, and 3.
10. If the above checks don't work, there is a possibility that the wires built in the frames are broken.

Problem #4 - Star lights on an individual rib are off

1. Check to make sure the two wires of the rib are firmly attached to the two Connecting Rings. Retighten all the screws.
2. Check to make sure the string light is not broken, if so, replace it.

For further assistance contact our service department